

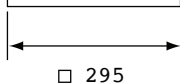

8 fante

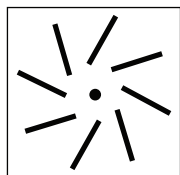

□ 295

16 fante

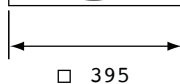
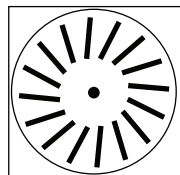

□ 395

24 fante

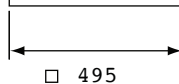
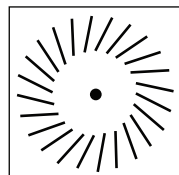

□ 495

16 fante

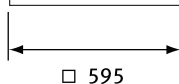
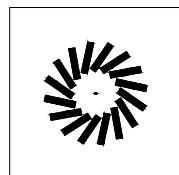

□ 595

24 fante

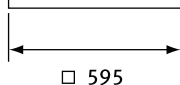
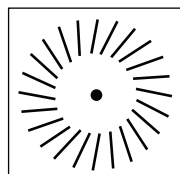

□ 595

32 fante

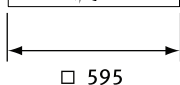
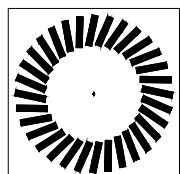

□ 595

48 fante

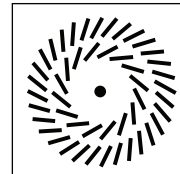

□ 595

DESCRIEREA PRODUSULUI

Difuzor elicoidal pătrat cu lamele reglabile.

UTILIZARE

Se utilizează cu precădere pentru refulare / introducere aer, dar și pentru aspirație / evacuare, în sisteme de ventilație și aer condiționat.



MATERIALE ȘI FINISARE

Sunt realizate din tablă de oțel. Finisajul standard este alb RAL9010 (vopsire electrostatică).

Alte finisaje sunt disponibile opțional. Lamele deflectoare din plastic negru

MONTAJ

Montaj cu șurub central în brida plenum. (A)
Direct în structura tavanului fals casetat. (B)

ACCESORII OPȚIONALE

Plenum pentru racord la tubulatură.

	Număr lamele	Q (m ³ /h)
295	8	180
395	16	320
495	24	430
595	24	430
595	48	880
595	16	320
595	32	640

DIMENSIUNI

Aceste produse sunt disponibile numai la dimensiunile standard mai jos menționate.

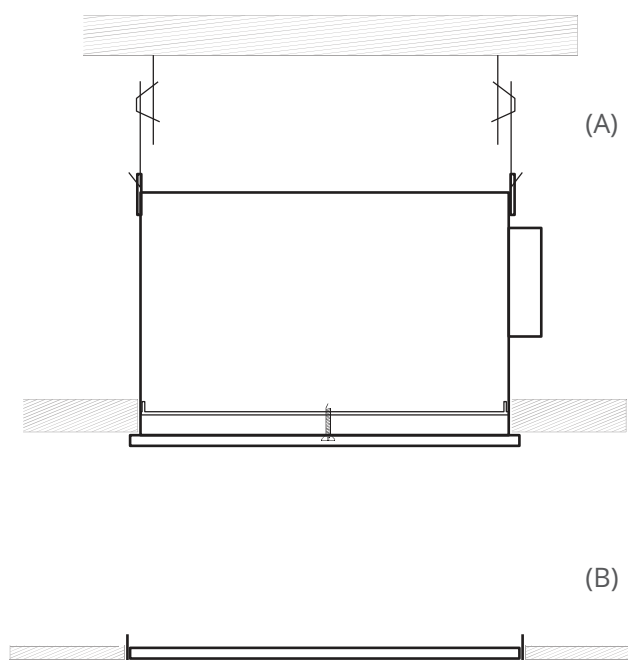

MODEL COMANDĂ

WDT B 595 / 24 ST +PL

Cod produs

Dimensiunea exterioară A

Nr lamele (corespunde dimensiuni)

ST - RAL9016 (standard)

RALxxxx - cod RAL opțional

PL - Plenum (a se specifica separat)

UTILIZARE

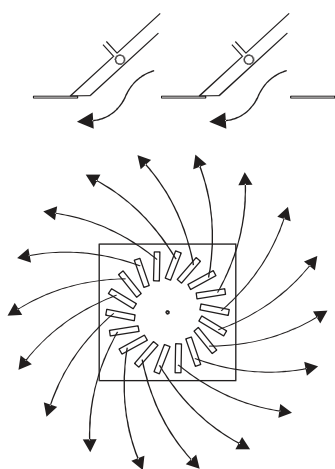

Difuzie orizontală uniformă.
Jet aer cu dispersie largă.
Utilizare: refulare/introducere.

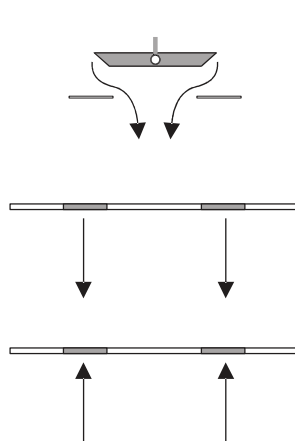

Difuzie verticală.
Utilizare: refulare/introducere sau aspirație / evacuare.

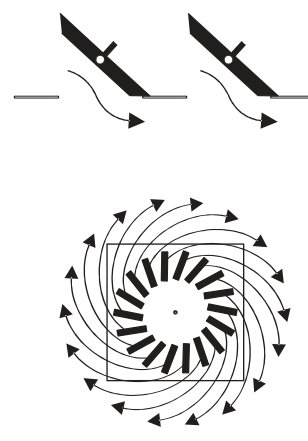

Difuzie orizontală uniformă.
Jet aer cu dispersie largă.
Utilizare: refulare/introducere.



DIRECȚII DE DIFUZIE

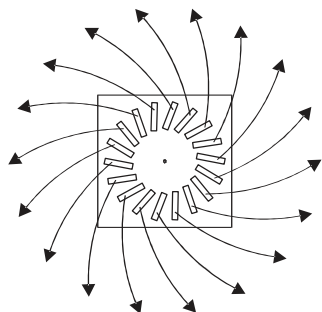

Difuzie uniformă circulară.

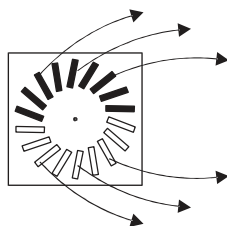

Difuzie în trei direcții.

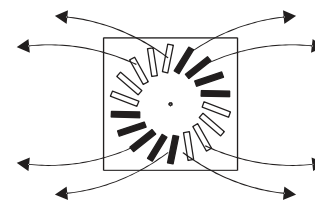

Difuzie bilaterală.

DATE TEHNICE

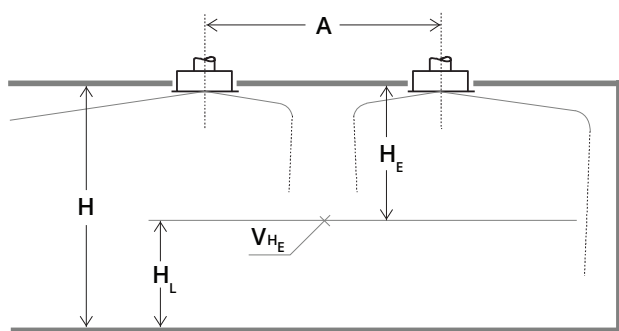

H = 2,5~4,0 m (înălțime încăpere)
HL = 1,8 m (zona ocupată)
HE = H - HL(m)
A = distanță amplasare WDT (m)
VHE = viteza aer la intrare în zona HL (m/s)

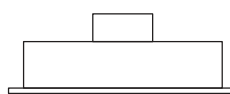

① WDT-B + Plenum cu stut superior



② WDT-B + Plenum cu stut lateral

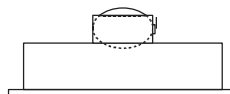

③ WDT-B + Plenum cu stut superior si clapeta de reglaj



④ WDT-B + Plenum cu stut lateral si clapeta de reglaj

WDT B 295/8

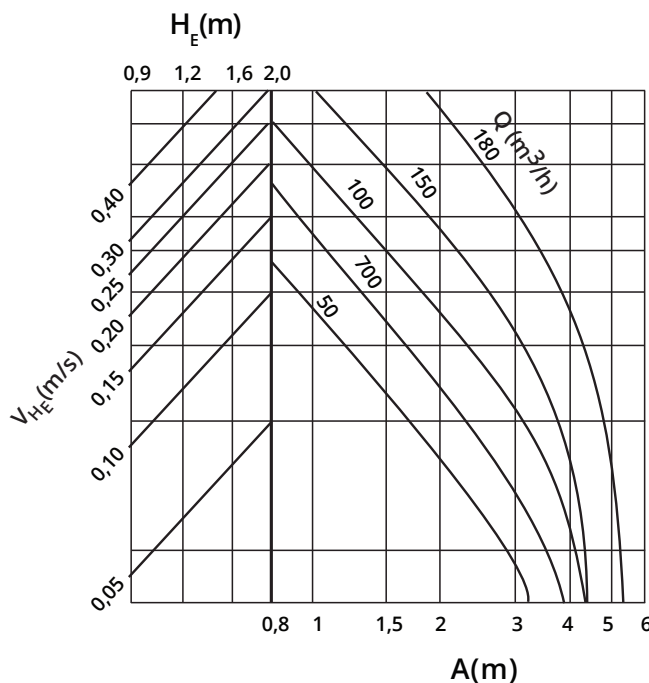
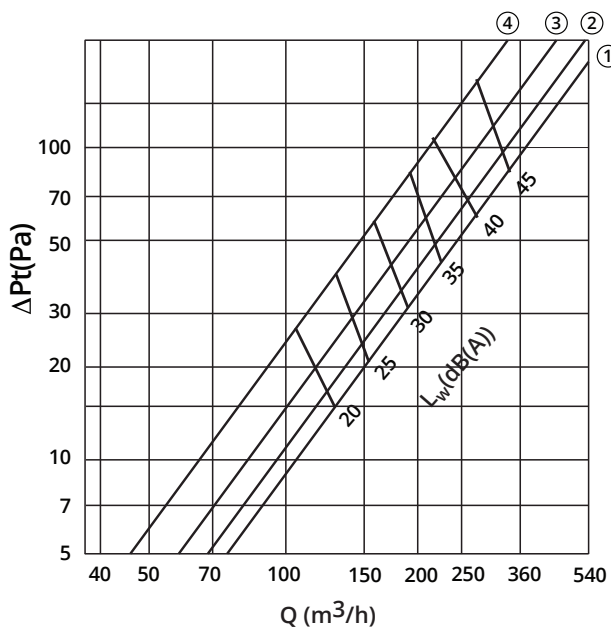



DATE TEHNICE

WDT B 395/16

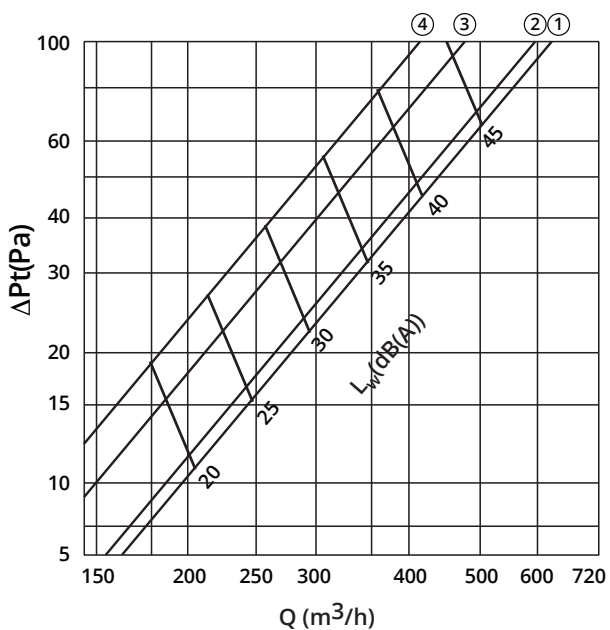

H_E (m)

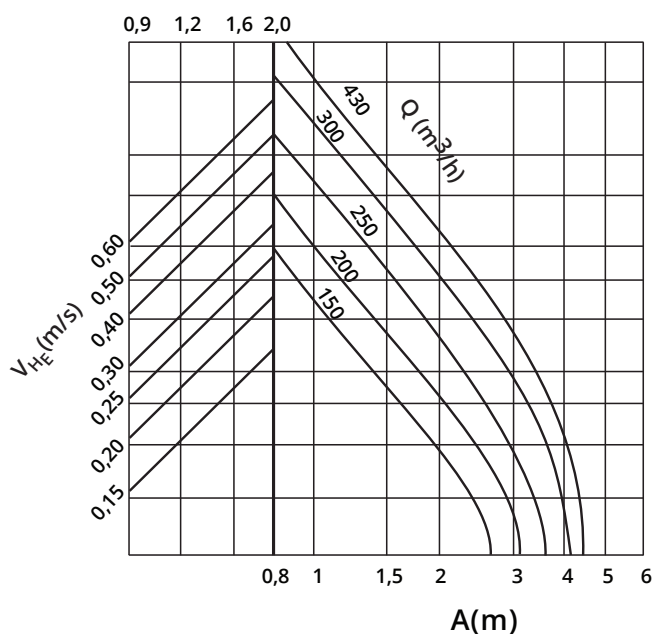

WDT B 495/24

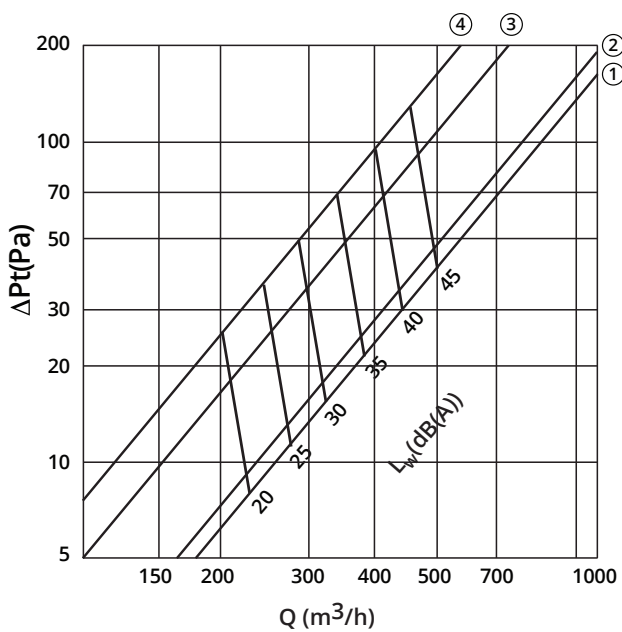

H_E (m)

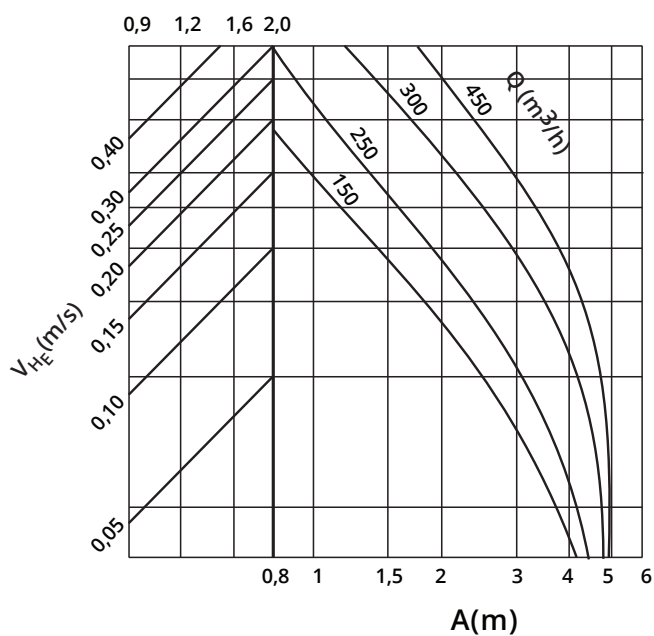



DATE TEHNICE

WDT B 595/24

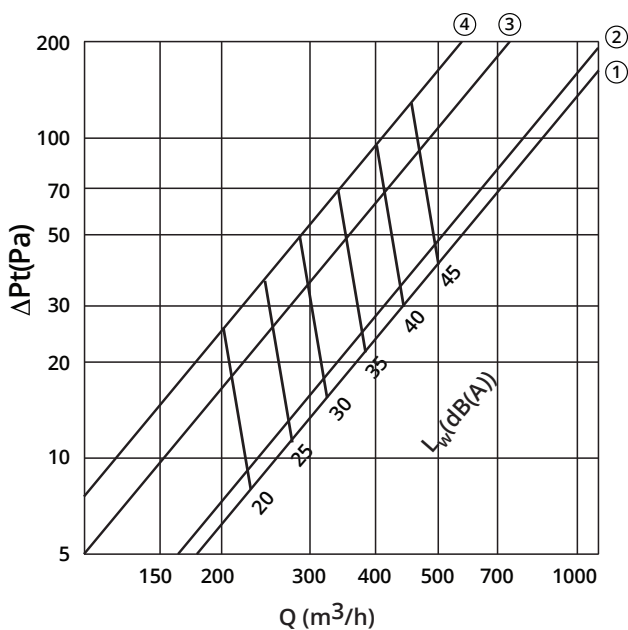

H_E (m)

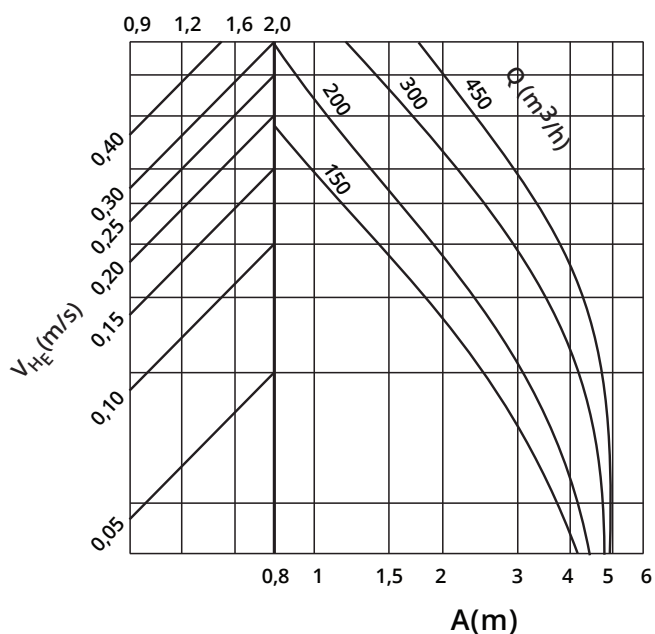

WDT B 595/48

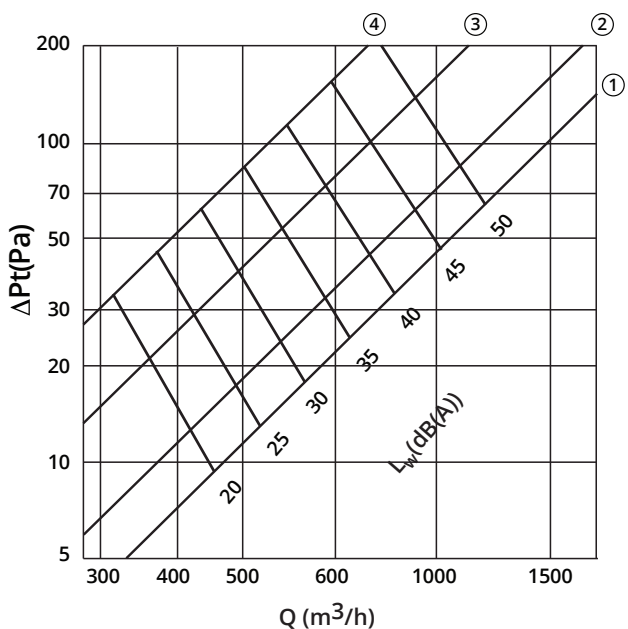

H_E (m)

